

Combination of Capacitor

Created: Tuesday, 30 August 2011 05:45 | Published: Tuesday, 30 August 2011 05:45 | Written by [Super User](#) | [Print](#)

Introduction to Combination of Capacitor

A capacitor can be charged by connecting the plates to the terminals of a battery, which are maintained at a potential difference V called the terminal voltage. When connection is achieved, the charges between the terminals and the plates are shared. For example, the plate that is connected to the negative (or positive) terminal will acquire some negative (or positive) charge. The sharing causes a momentary reduction of charges on the terminals, and a decrease in the terminal voltage.

A circuit composed solely of components connected in a series is known as a **series circuit**; likewise, one connected completely in parallel is known as a **parallel circuit**.

In a series circuit, the current that runs through each of the components is the same, and the [voltage](#) across the components is the sum of the voltages across each component. In a parallel circuit, the voltage that runs across each of the components is the same, and the total current is the sum of the currents running through each component.

Capacitors in Series

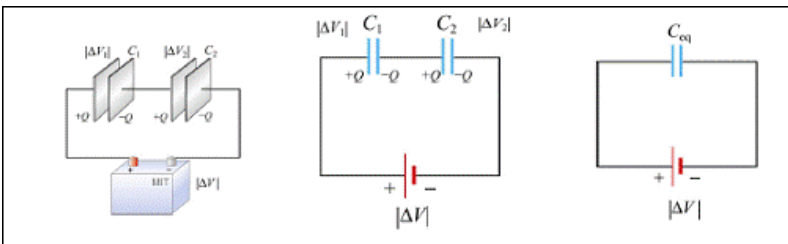

Suppose two initially uncharged capacitors C_1 and C_2

are connected in a series, as shown in the figure below. A potential difference $|\Delta V|$ is then applied across both capacitors.

The left plate of capacitor 1 is connected to the positive terminal of the battery and becomes positively charged with a charge $+Q$, while the right plate of capacitor 2 is connected to the negative terminal and becomes negatively charged with charge $-Q$ as electrons flow in. The inner plates were initially uncharged; now the outside plates each attract an equal and opposite charge. Consequently, the right plate of capacitor 1 will acquire a charge $-Q$ and the left plate of capacitor will acquire a charge $+Q$.

[Capacitors](#) follow the same law using the reciprocals. The total [capacitance](#) of capacitors in series is equal to the [reciprocal](#) of the sum of the reciprocals of their individual capacitances:

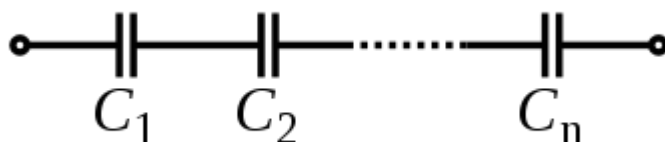

$$\frac{1}{C_{\text{total}}} = \frac{1}{C_1} + \frac{1}{C_2} + \dots + \frac{1}{C_n}$$

The working voltage of a series combination of identical capacitors is equal to the sum of voltage ratings of individual capacitors. This simple relationship only applies if the voltage ratings are equal as well as the capacitances. However, the division of [DC voltage](#) between the capacitors is dominated by the leakage resistance of the capacitors, rather than their capacitances, and this has considerable variation. To counter this, equalizing resistors may be placed in parallel with each capacitor that effectively adds to the leakage current.

If two or more components are connected in parallel they have the same potential difference ([voltage](#)) across their ends. The

potential differences across the components are the same in magnitude, and they also have identical polarities. The same voltage is applicable to all circuit components connected in parallel. The total current I is the sum of the currents through the individual components

Capacitors in Parallel

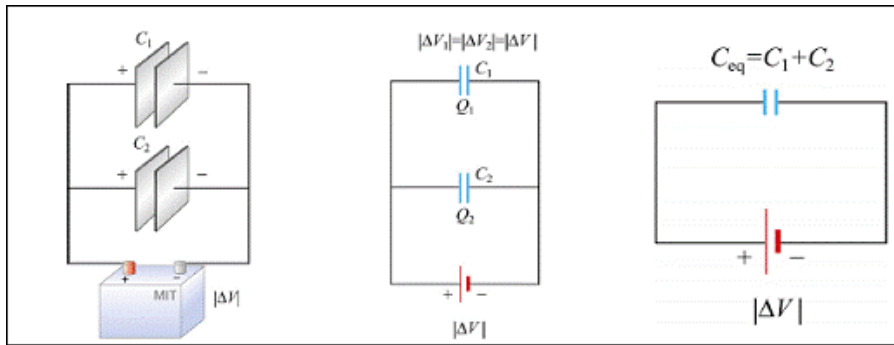

Suppose we have two capacitors, C_1 with

charge Q_1 , and C_2 with charge Q_2 , and that they are connected in parallel, as shown in the figure above. The left plates of both capacitors C_1 and C_2 are connected to the positive terminal of the battery and have the same electric potential as the positive terminal. Similarly, both right plates are negatively charged and have the same potential as the negative terminal.

Thus, the potential difference ΔV is the same across each capacitor. This gives

$$C_1 = Q_1 / \Delta V \quad C_2 = Q_2 / \Delta V$$

$$Q_{eq} = Q_1 + Q_2$$

$$= (C_1 + C_2) \Delta V$$

[Capacitors](#) follow the same law using the reciprocals. The total [capacitance](#) of capacitors in parallel is equal to the sum of their individual capacitances:

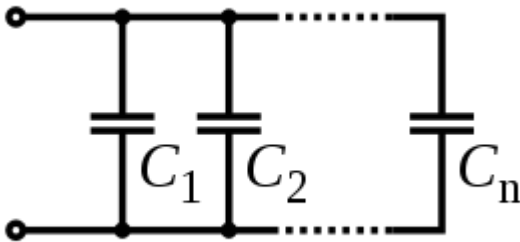

$$C_{total} = C_1 + C_2 + \dots + C_n$$

The working voltage of a parallel combination of capacitors is always limited by the smallest working voltage of an individual capacitor.

Dielectric

In many capacitors there is an insulating material such as paper or plastic between the plates. Such material, called a dielectric, can be used to maintain a physical separation of the plates.

Polar Dielectric

Polar dielectrics are substances that have polar atoms/molecules intrinsically but are randomly arranged. On application of an external electric field, they are polarized parallel to the external electric field.

Net electric field inside dielectric.

$$\vec{E} = \vec{E}_0 - \vec{E}_i \quad \vec{E}_i = \text{electric field due to induced charges}$$

$$\vec{E}_i = \vec{E}_0 \left[1 - \frac{1}{K} \right] \quad \sigma - \text{surface charge density of capacitor plates}$$

$$q_i = q \left[1 - \frac{1}{K} \right] \quad \sigma_i - \text{induced charge density}$$

$$\sigma_i = \sigma \left[1 - \frac{1}{K} \right]$$

Capacitance of a parallel plate capacitor having dielectric slabs in series.

$$C = \frac{A \epsilon_0}{\left[\frac{t_1}{K_1} + \frac{t_2}{K_2} + \dots \right]}$$

Want to know more about combinations of capacitors? [Click here](#) to schedule a live session with an eAge eTutor!

[eAgeTutor.com](#) is the premium online tutoring provider. Using materials developed by highly qualified educators and leading content developers, a team of top-notch software experts, and a group of passionate educators, eAgeTutor works to ensure the success and satisfaction of all of its students.

[Contact us](#) today to learn more about our guaranteed results and discuss how we can help make the dreams of the student in your life come true!

Reference links:

- <http://en.wikipedia.org/wiki/Voltage>
- <http://en.wikipedia.org/wiki/Capacitance>
- <http://www.kpsec.freeuk.com/acdc.htm>

Category: [ROOT](#)

Joomla SEF URLs by Artio